

- ❑ **The strong and compact vacuum lifter for machine hoisting operation**
- ❑ **For even and rough surfaces**
- ❑ **For operation with electric motor 230 V – 50 Hz**
- ❑ **Maximum carrying capacity 2,000 kg**

## Uni-Levator: the powerful vacuum lifter für machine hoisting operation

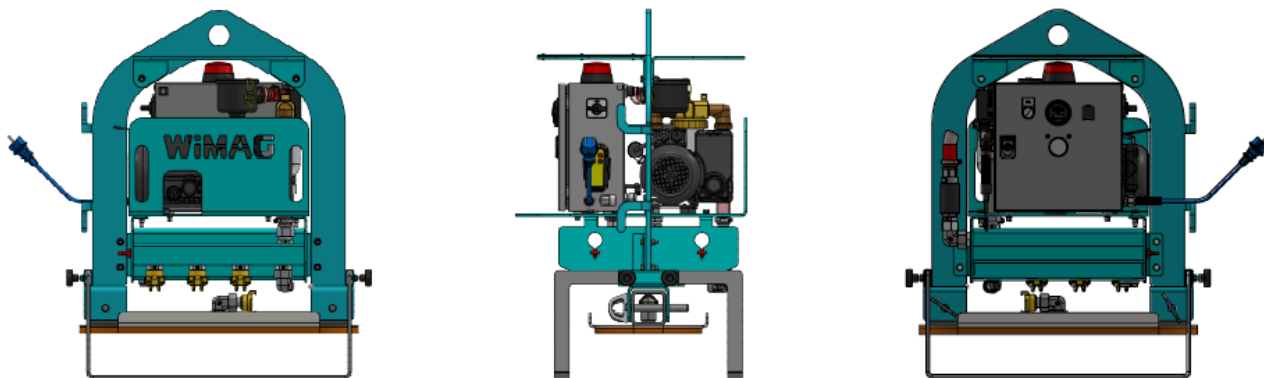

Almost all smooth/rough and even surfaces can be easily suctioned and safely transported with the Uni-Levator. The Uni-Levator only releases the plate again when you want it to: open the valve for this purpose.

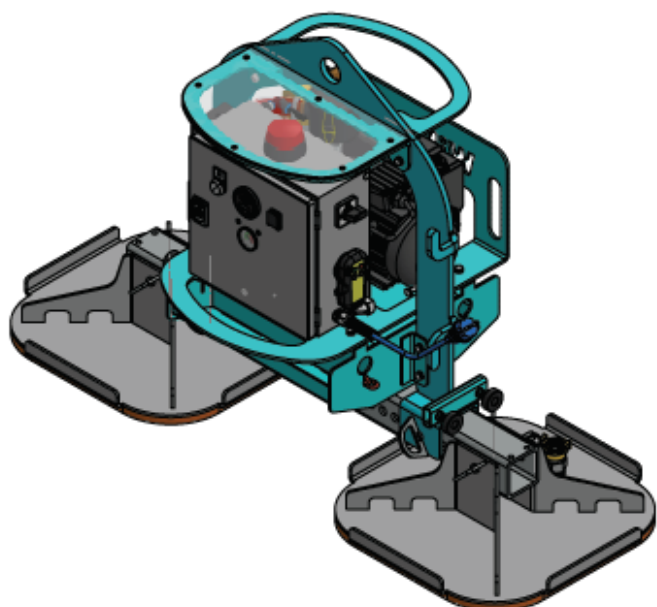

Uni-Levator with 2 suction plates SP 500 and beam

### Specification

The oil-lubricated vane-type vacuum rotary pump is designed for non-stop operation and is characterised by its extremely smooth running and performance.

The vacuum chamber of the suction plate is sealed with an elastic rubber. The sealing is self-adhesive and can be easily changed. To protect the sealing equipment can be placed on both resting feet.

The Uni-Levator is equipped as standard with a vacuum storage, a water trap, a pressure gauge, a warning device and a safety valve.

### Accessories

Remote control

Generator

Special suction plates on request

Order No.	Model	Carrying Capacity	Length x Width x Height	Weight
<b>841 100</b>	Uni-Levator with suction plate SP 400	400 kg	620 x 541 x 757 mm 670 x 280 mm	100 kg
<b>012 247</b>	Beam 600 mm	2.000 kg	600 x 80 x 80 mm	25 kg
<b>012 248</b>	Beam 1.100 mm	2.000 kg	1.100 x 80 x 80 mm	48 kg
<b>860 408</b>	Suction plate SP 250	250 kg	425 x 275 mm	8 kg
<b>860 409</b>	Suction plate SP 500	500 kg	500 x 500 mm	16 kg
<b>860 411</b>	Suction plate SP 1000	1.000 kg	650 x 650 mm	27 kg
<b>841 300</b>	Remote control			
<b>841 310</b>	Petrol powered electric generator inverter soundproofed 230 V-50 Hz with suspension		555 x 460 x 767 mm	58 kg
<b>841 402</b>	Safety chains according to EN 13155, length 3.0 m			3 kg

\* Maximum carrying capacity at a low pressure of at least -0.65 bar.  
If the surface is very rough or very porous, the carrying capacity is reduced or will be zero.  
The vacuum lifter may only be used near to the ground.